



NITE-EYES™ Railroad Driving Light

Part No.: #8816-0005

A BRIGHT IDEA... FOR ANY VEHICLE!™

- Utilities
- Wreckers
- Construction
- Industrial
- Public Works
- Police, Fire, and Ambulance
- Agriculture
- Recreation
- Heavy-Duty Trucks
- Railroad
- Marine
- Camping/RV
- Farming

FOR ADDITIONAL INFORMATION

Visit us at

www.unityusa.com.

Information available on:

- The company
- Products
- Replacement parts
- Mounting templates
- Installation instructions
- Distributor Search
- Application Search



DURABLE

- Designed to pass leading OEM shaker and 1,000,000 mile durability tests!
- High impact ABS housing will not rust or corrode!
- Lamps are cushioned to dampen vibration for longer bulb life!
- Stainless Steel fasteners will not corrode!

Unity Manufacturing has provided top quality emergency and auxiliary lighting products since 1918. Unity's Railroad Driving Light comes in a rugged, high-impact ABS housing to provide unmatched performance, reliability, and durability. The Driving Light utilizes an H3 bulb for availability and economy, which is rated at 245,000 candlepower, 100 watts, and 100 hours lamp life. The lamp has a polycarbonate lens that is break resistant, virtually indestructible, and contains a U. V. ray inhibitor to prevent clouding or yellowing. The light features a spot beam allowing you to see further with a tighter more controlled beam focused on the rails for maximum visibility and added safety.

More Light Means More Safety!

- Brighter (245,000 CP)
- Whiter
- Tighter/Controlled Beam
- Reduced Glare

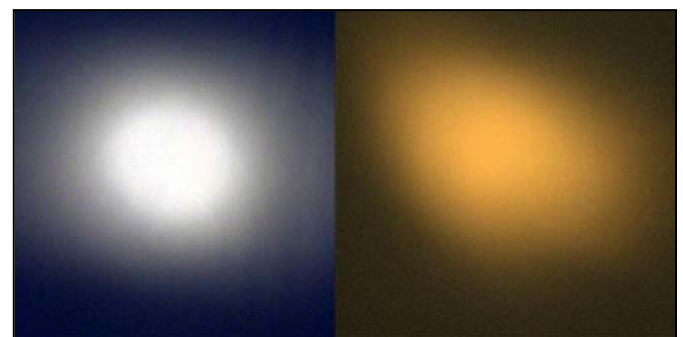

Unity Light

Conventional Light



NITE-EYES™ Railroad Driving Light

Part No.: #8816-0005



Dimensions

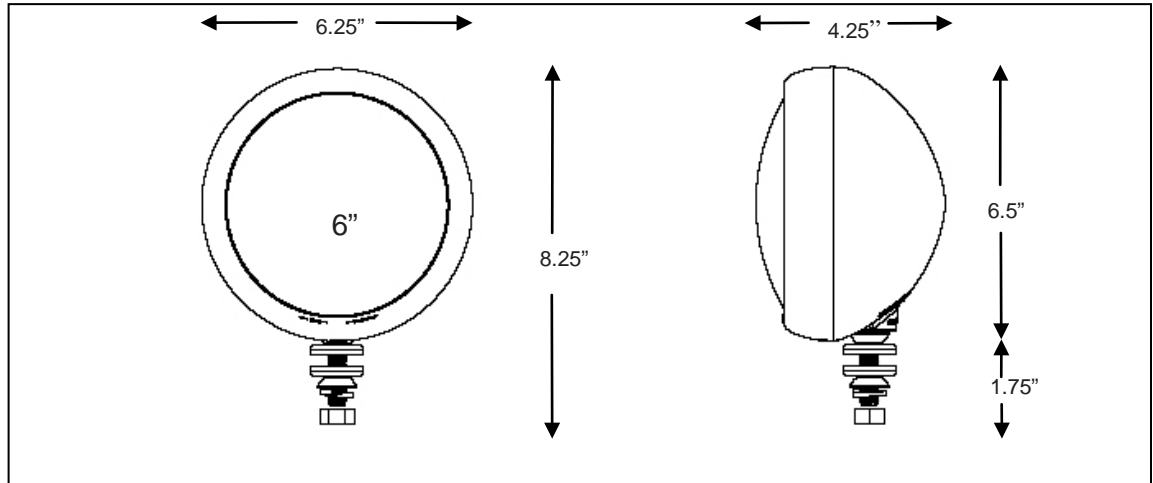

The Railroad Driving Light, Part # 8816-0005 is 6.25" Wide X 8.25" High X 4.25" Deep. The top part of the light measures out at 6.5" high and the extra leveling washers/bracket measure to be 1.75" high. The leveling washers allow for the Railroad Driving Light to be adjustable by 5° up and down in order to find the optimal position for the lights on the Rail Truck.

Specification

FEATURE	SPECIFICATION
Housing Material	6" round high impact ABS plastic
Finish	Black finish
Lamp/Bulb	Replaceable 100 W H3 Bulb with 100 hours lamp life in a lamp with a polycarbonate lens that contains U.V. ray inhibitor.
Dimensions	6.25" Wide X 8.25" High X 4.25" Deep
Voltage	13.0 Volts
Amperage	7.69 Amps
Candlepower	245,000 CP (SAE Test Results)
Bracket	7/16" Stud with leveling washers
Wiring	60 inch, 16ga. wire with bullet terminal

Features

- ABS Hi-Impact Plastic
- Polycarbonate Lens
- Replaceable 100 W H3 Bulb
- 245,000 CP
- 7/16" Stud
- Bracket (± 5° Adjustable)
- 60" wire with bullet terminal
- Sharp Beam with less glare



Unity Manufacturing Co.
 1260 N. Clybourn Ave.
 Chicago, IL 60610
 Phone: 312-943-5200
 Fax: 312-943-5681
 E-mail: info@unityusa.com
 Form: 143-RR 2/10

REPLACEMENT PARTS

- U-H3-100W Bulb
- U-7682 Lamp Assembly
- 8173-0002 Black Ring
- 3334 Mounting Hardware

OTHER UNITY® PRODUCTS

THE BEAM®

- Post-Mount Spotlights
- Rooflights
- Decklights

UNITY®HID

- Post-Mount Spotlight

NITE-EYES™

- Foglights
- Passing Lights
- Driving Lights
- Off-Road Lights
- Worklights

UNILITE™

- Hand-Held Spotlight

UNIBEACON™

- Rotating Warning Lights

EYE BEAM™

- Spotlight and Officer Warning System