

UNITY®LED Post-Mount Spotlight

Part No.: 335 Series Chrome 335-0002 Series Black

A BRIGHT IDEA... FOR ANY VEHICLE!SM

- Utilities
- Wreckers
- Construction
- Industrial
- Public Works
- Police, Fire, and Ambulance
- Agriculture
- Recreation
- Heavy-Duty Trucks
- Railroad
- Marine
- Camping/RV
- Farming

FOR ADDITIONAL INFORMATION

Visit us at

www.unityusa.com.

Information available on:

- The company
- Products
- Replacement parts
- Mounting templates
- Installation instructions
- Distributor Search
- Application Search



Powered by Whelen SUPER-LED®

Unity Manufacturing has provided top quality emergency and auxiliary lighting products since 1918. Unity's Post-Mount Spotlight comes in a rugged, high-impact ABS Chrome or Black housing to provide unmatched performance, reliability, and durability. The Spotlight utilizes LED technology rated at 2000 lumens output, 30 watts, and up to 50,000 hours lamp life. The lamp has a replaceable, hard-coated, polycarbonate lens that is break resistant, virtually indestructible. The instantly aimable light is easy for anyone to use. Whether you need additional light to illuminate your work area, to help you find street signs or house numbers, or to follow the path of a broken power line, the UNITY®LED post-mount spotlight is a *bright idea for any vehicle!*sm

See Better and Work Safer!

- Instant aimable light when and where you want it!
- Bright light virtually turns the night into day!
- Easy to install on virtually any vehicle!

More Light Means More Safety!

- Brighter (2000 lumens)
- Whiter
- Tighter/Controlled Beam (4° x 4° spread)
- Reduced Glare



Conventional Light

UNITY®LED



UNITY® LED Post-Mount Spotlight

Part No.: 335 Series Chrome

335-0002 Series Black

Dimensions

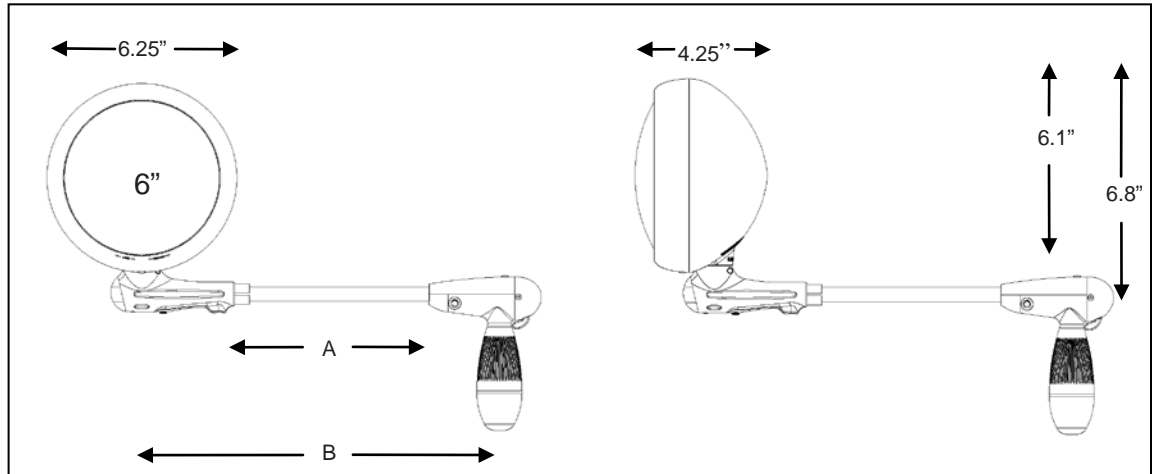

Part #	A	B	Part #	A	B	Part #	A	B
335A	6 1/2	12	335FP	17 5/8	22 1/2	335N	4 1/4	9 1/8
335B	4 3/4	10 1/4	335G	14	19 1/2	335O	8	13 1/2
335C	10 7/8	15 1/2	335GM	9	14 1/2	335OS	21 1/8	26
335CL	10	15 1/2	335H	5 7/8	11 3/8	335P	12 7/8	17 1/2
335DC	10 1/2	16	335K	7 5/8	12 1/2	335PL	12	17 1/2
335F	15 7/8	20 1/2	335MS	18 7/8	23 3/4	335V	7 1/2	13
335FL	17	22 1/2						

Specification

FEATURE	SPECIFICATION
Housing Material	6" round high impact ABS plastic
Finish	Black or chrome finish
Lamp/Bulb	LED lamp assembly with replaceable, hard-coated polycarbonate lens. 2000 lumens, 30 watts, 50,000 hours lamp life..
Dimensions	Head: 6.25" W x 6.1" H x 4.25" D
Voltage	12.8 Volts
Amperage	2.3 Amps
Output	2000 lumens
Mounting Bracket	Installation brackets are sold separately and fit specific vehicles based on make, model, and year of the vehicle.
Wiring	36" wire

Features

- ABS Hi-Impact Plastic
- Replaceable Polycarbonate Lens
- 2000 lumens
- Installation Kits sold separately and fit specific makes, models, and year. Visit www.unityusa.com for application guide.
- Sharp Beam with less glare - 4° x 4°

REPLACEMENT PARTS

- 5547-0017 Chrome Shell
- 5547-0019 Black Shell
- 8173 Chrome Ring
- 8173-0002 Black Ring
- U-6701-0101 Handle Assembly
- U-P46SLC LED Lamp Assembly

OTHER UNITY® PRODUCTS

THE BEAM®

- Post-Mount Spotlights
- Rooflights
- Decklights

UNITY® HID

- Post-Mount Spotlight

NITE-EYES™

- Foglights
- Passing Lights
- Driving Lights
- Off-Road Lights
- Worklights

UNILITE™

- Hand-Held Spotlight

UNIBEACON™

- Rotating Warning Lights

EYE BEAM™

- Spotlight and Officer Warning System



Unity Manufacturing Co.
1260 N. Clybourn Ave.
Chicago, IL 60610
Phone: 312-943-5200
Fax: 312-943-5681
E-mail: info@unityusa.com
Form: 143-LED 8/10